

MAX300-AIR

Environmental Mass Spectrometer



PRODUCT NOTE



- Ambient Air Monitoring
- Flare Gas Analysis
- Industrial Health and Safety

Introducing the MAX300-AIR™

Be Safe, Be Clean, Be Compliant

Mass spectrometry is a powerful tool for environmental analysis. In today's world, successful manufacturers are concentrating their efforts on safety and regulatory compliance. Often, this makes the fast, accurate analysis of air and stack gas samples essential. The Extrel® MAX300-Air uses cutting-edge quadrupole mass spectrometer technology to measure contaminant levels in air, or process samples, from multiple points within the facility, and reports these values to the control system in real-time.

Based on decades of proven performance in industrial hygiene and ambient air monitoring, the MAX300-AIR provides the stability and precision of a laboratory-grade analytical instrument in a rugged platform optimized for continuous operation in a manufacturing environment.



Features

- Quantitative analysis of individual contaminants
- ppt detection limits
- Analysis time in seconds
- Multipoint sample systems for total site monitoring
- High precision and accuracy for safety and regulatory reporting
- Minimal maintenance required

MAX300-AIR Measurements

Toxic chemical release
Total sulfur
TWA exposure values
BTU (energy content)
Explosive limit analysis

Industrial Sites

Petrochemical
Polymer resins
Pesticides/herbicides
Ammonia fertilizer
Semiconductor
Synthetic fibers
Pharmaceutical solvents
Detergents
Adhesives

The MAX300-AIR measures trace levels of almost any industrial contaminant:

Hydrogen sulfide
Benzene
Toluene
Xylene
Styrene
Chlorobenzene
Acetone
Acrylonitrile
Acetonitrile
Vinyl acetate
Arsine
Freons
Ethylene dichloride (EDC)
Vinyl chloride monomer (VCM)
Trichloroethane
Carbon tetrachloride
Dimethyl sulfide (DMS)
Dimethyl sulfate (DMSO4)
Ammonia
Cyclohexane
Methyl ethyl ketone (MEK)
Methyl tertiary-butyl ether (MTBE)
Methyl iodine
Vinyl bromide
Dioxanes
Pyrrole

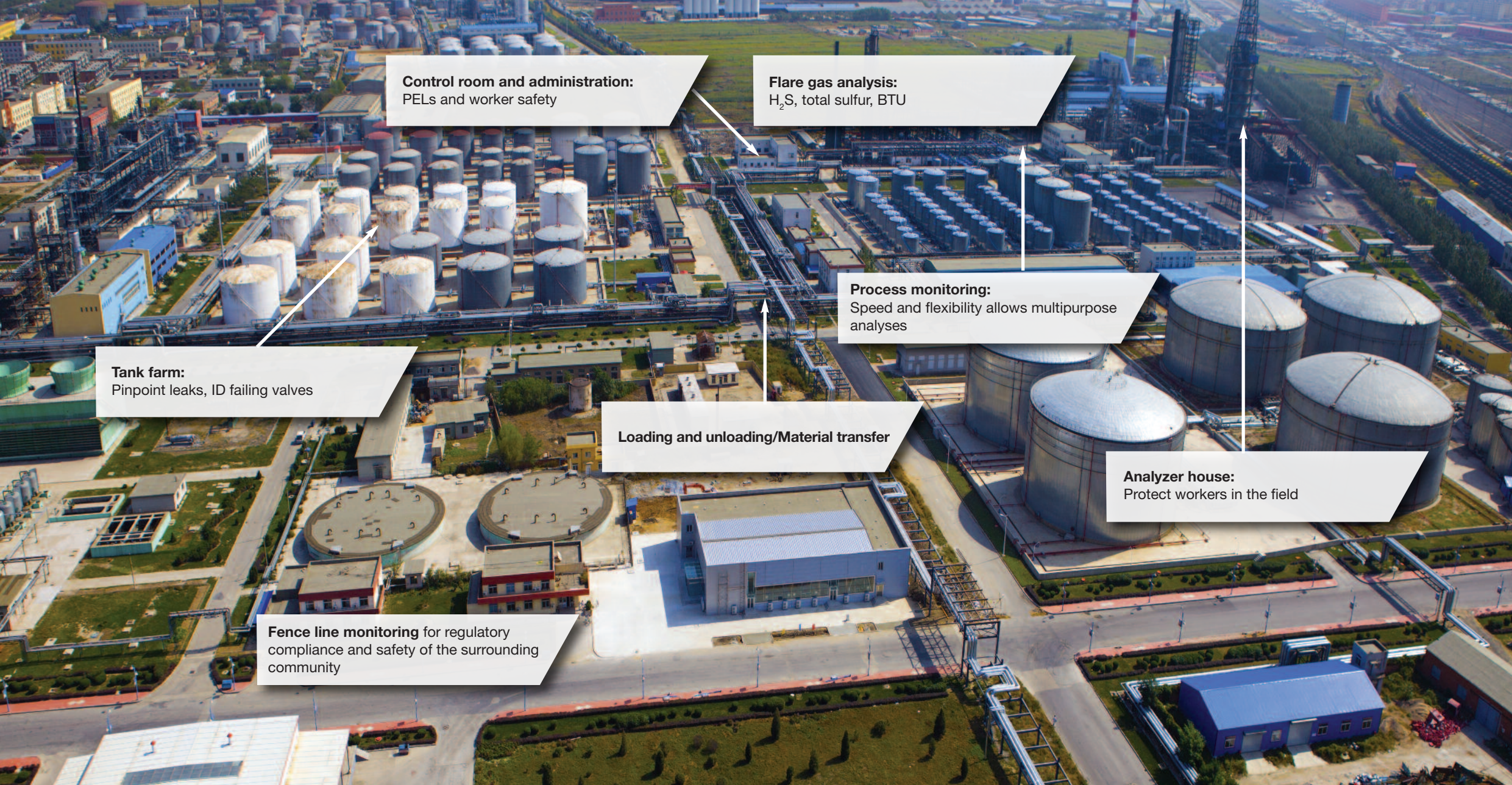

Control room and administration:
PELs and worker safety

Flare gas analysis:
H₂S, total sulfur, BTU

Process monitoring:
Speed and flexibility allows multipurpose analyses

Tank farm:
Pinpoint leaks, ID failing valves

Loading and unloading/Material transfer

Analyzer house:
Protect workers in the field

Fence line monitoring for regulatory compliance and safety of the surrounding community

Ultra Trace Detection Membrane Inlet Mass Spectrometry

The membrane inlet uses a silicone material to concentrate VOCs relative to the air in the sample. A MAX300-AIR with the membrane inlet has the sensitivity to measure **low ppt contamination**.

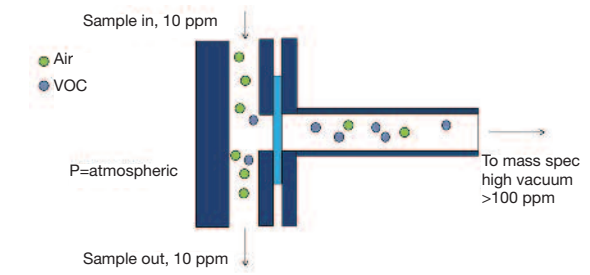
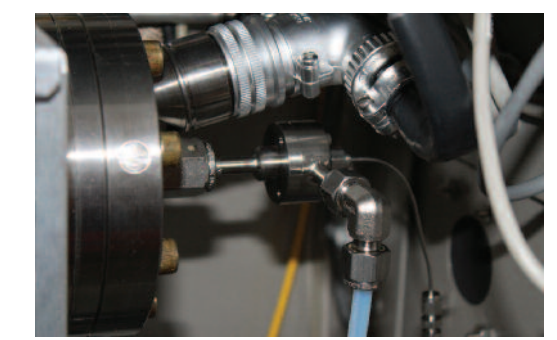

MAX300-AIR Low Detection Limit (LDL) Examples

| Compound | Standard LDL | Membrane Inlet LDL |
|----------|--------------|--------------------|
| Benzene | 10 ppb | 10 ppt |
| Pyrrrole | 10 ppb | 10 ppt |
| VCM | 20 ppb | 2 ppb |

EXTREL'S FASTVALVE SYSTEM FOR TOTAL PLANT MONITORING

Sampling Configuration: 16, 31, 40, 80, 120, 160+ Sample Points

The speed of the MAX300-AIR allows one analyzer to monitor sample points spread throughout the site without sacrificing fast updates. Rotary valve options with 16 and 31 ports exist for smaller installations, while the high-flow, zero dead-volume FASTvalve can pull sample from 40, 80, 120, 160, or more points.

MAX300 FASTvalve Includes:

- High flow sample pump
- Complete flow rack system
- Temperature control up to 200°C
- Multiple valves can be installed in series

Typical Sample Tubing:

- 1/8" or 1/4"
- PTFE
- Stainless Steel
- Coated Steel



Optional sample point filter

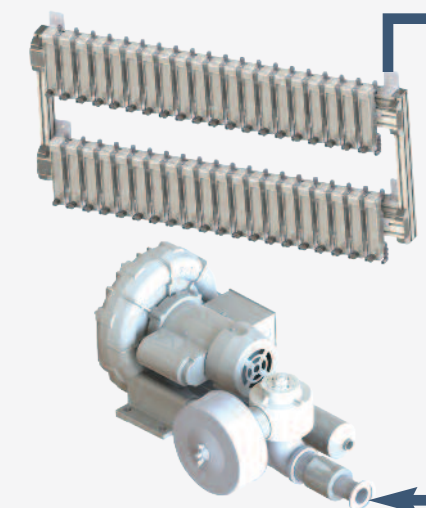

High flow pump loops all samples simultaneously

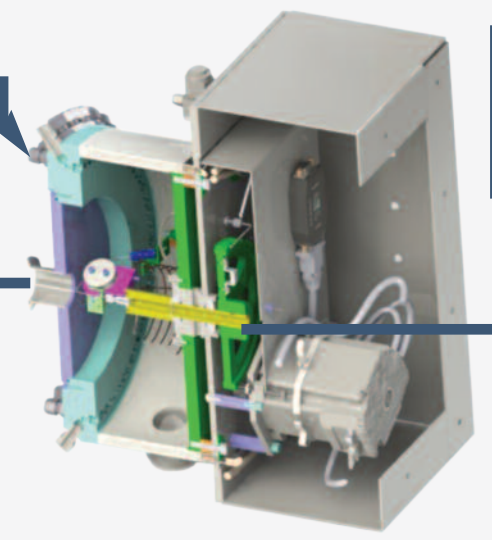

MAX300 FASTvalve

Data to the Control Room/PLC

- Transmission options:
- 2 Wire
 - 4 Wire
 - Fiber optic



Speed, Sensitivity, Flexibility

The MAX300-AIR is an analytical platform with the sensitivity to measure trace level contamination and the speed to provide a single analyzer solution for total site monitoring.

System Highlights:

- Detectable compounds: Any gas or vapor sample
- Detection range: 100% - 10 ppb standard, 10 ppt with membrane inlet*
- Number of sample streams: 16, 31, 40, 80, 120, 160+
- Analysis rate: <0.4 seconds per component
- Number of components: Unlimited
- Number of analysis routines: Unlimited
- Number of user-configurable data tags: Unlimited
- Analysis precision: <0.25% relative standard deviation**
- Stability: <0.5% relative standard deviation over 30 days**
- Dual filament:
 - One active
 - One spare with automatic switchover
- Maintenance: Typically two PMs per year
- Manual or fully-automated calibration and validation
- Mass range options: 1-200, 300, or 500 amu
- 19 mm high-transmission quadrupole filter

*Documented on trace benzene in air

**Based on the analysis of 1% argon

Low Maintenance, Easy to Use: The Questor5 software that drives the MAX300-AIR is designed for fully-automated, industrial site monitoring, measuring all sample points in a fully-customizable sequence. The intuitive web-based interface allows the user to check instrument status, pull up data, or run a validation sequence from anywhere on the plant network, while maintaining government and industry security standards for login and electronic record keeping (21 CFR 11).

Combining a powerful, user-friendly interface with industrial-grade hardware, the MAX300-AIR is a 24/7 environmental analyzer with a documented uptime >98%.

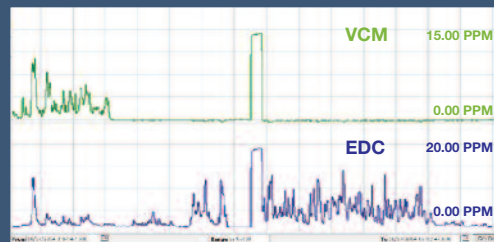

PPM level breakouts of VCM and EDC. The MAX300-AIR provides accurate speciated data, free of inference, despite the chemical similarities of the two components.



Extrel's 19 mm quadrupole next to a common 6 mm filter. The larger device provides greater ion transmission for unparalleled sensitivity and signal stability.

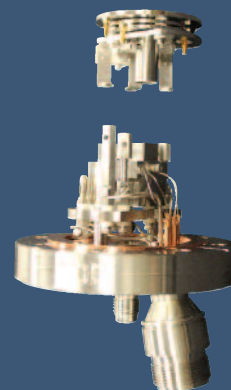

The MAX300-AIR disposable, plug-and-play ionizer eliminates the cleaning requirement. It includes dual filaments: one active and one spare.

MAX300-AIR System Specifications

Power Supply Options:

- 110 VAC, 50/60 Hz, Two 15 Amp circuits
- 230 VAC, 50/60 Hz, One 20 Amp circuit

Power Consumption:

- Nominal 2500 Watts
- Startup 2750 Watts
- Heat Load: 2500 Watts (8500 BTU/Hr)

Weight:

- Standard Enclosure: 420 lbs (190 kg)
- ATEX Enclosure: 560 lbs (254 kg)
- Optional cart: 40 lbs (18 kg)

Ambient Requirements:

- Temperature: -4°F to 120°F (-20°C to 49°C)
- With A/C, cold start $\geq 54^\circ\text{F}$ (12°C)
- Area Classification Options:
 - General Purpose
 - Class 1, Division 2 Groups B, C, D, T3
 - Class 1, Division 1 Groups B, C, D, T3
 - ATEX Zone 1 or Zone 2, Group II B +H2, T4

Additional Utilities:

- Purge gas (for hazardous area installations)
- Base calibration requirement: 2 gas bottles

Data System and Communications:

- System control interface options: Ethernet, RS-422 4-wire
- Login security levels: Administrator, User, Viewer
- External communications:
 - Ethernet, Modbus serial, digital I/O, analog I/O, OPC

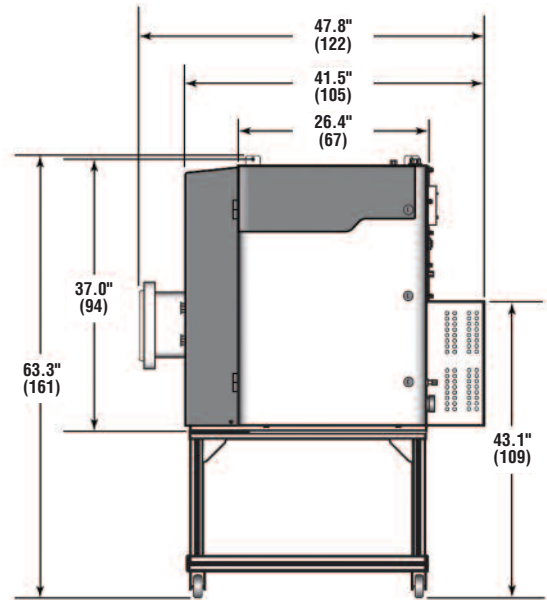

Dimensions in Inches (cm)

MAX300-AIR standard enclosure dimensions with A/C and Cart

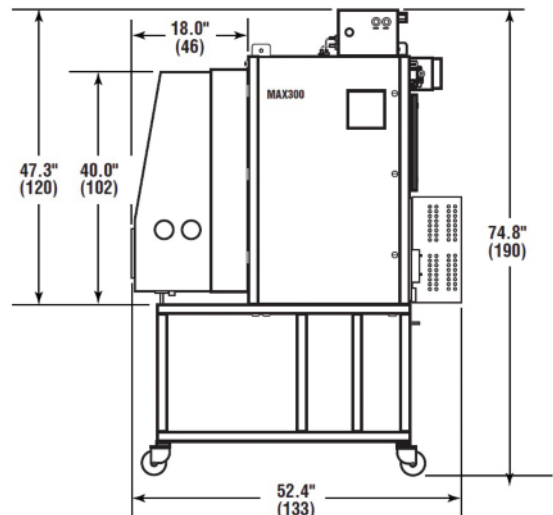

Dimensions in Inches (cm)

MAX300-AIR ATEX enclosure dimensions with A/C and Cart

Support: For over 50 years, Extrel has been committed to providing the highest quality support services for the thousands of instruments installed worldwide. Factory-trained-and-certified personnel offer industry-leading support to Extrel customers at every stage of the environmental monitoring application.